

ISO 20022-based payment transactions

Access point forum

Olav Astad Kristiansen

Project Manager

Chair Nordic e-Procurement Network

Agency for Public Management and eGovernment

Background #1

Government Agency for Financial Management (DFØ)

- ▶ DFØ administrates the framework agreement with banks for central government agencies for Norway.
- ▶ Agency for Financial Management (DFØ) requires common standard for securing and transportation of file-based payment transactions in its future agreements with banks, using CEF eDelivery and ASiC archive.

STATUS

Participants in the project

► Banks:

- DNB
- Nordea
- Sparebank1
- Danske bank
- Eika bankene
- Swedish Bankers Association
- Bits

► Public entities

- DFØ
- NAV

► Access points and ERP vendors:

- Unit4
- UniMicro
- Nets
- Tripletex
- Logiq
- Visma

► Interest from:

- Sweden
- Finland
- Denmark

THE SOLUTION

Components

- ▶ Reuse of PEPPOL profile of CEF eDelivery
- ▶ New components at transport layer:
 - ▶ ASiC archive
 - ▶ Modification to MDN
 - ▶ REM
- ▶ New components at message encryption layer:
 - ▶ End-to-end encryption
- ▶ New domain layer
 - ▶ Receipts (all corners)

Four corner model – SEPA payments

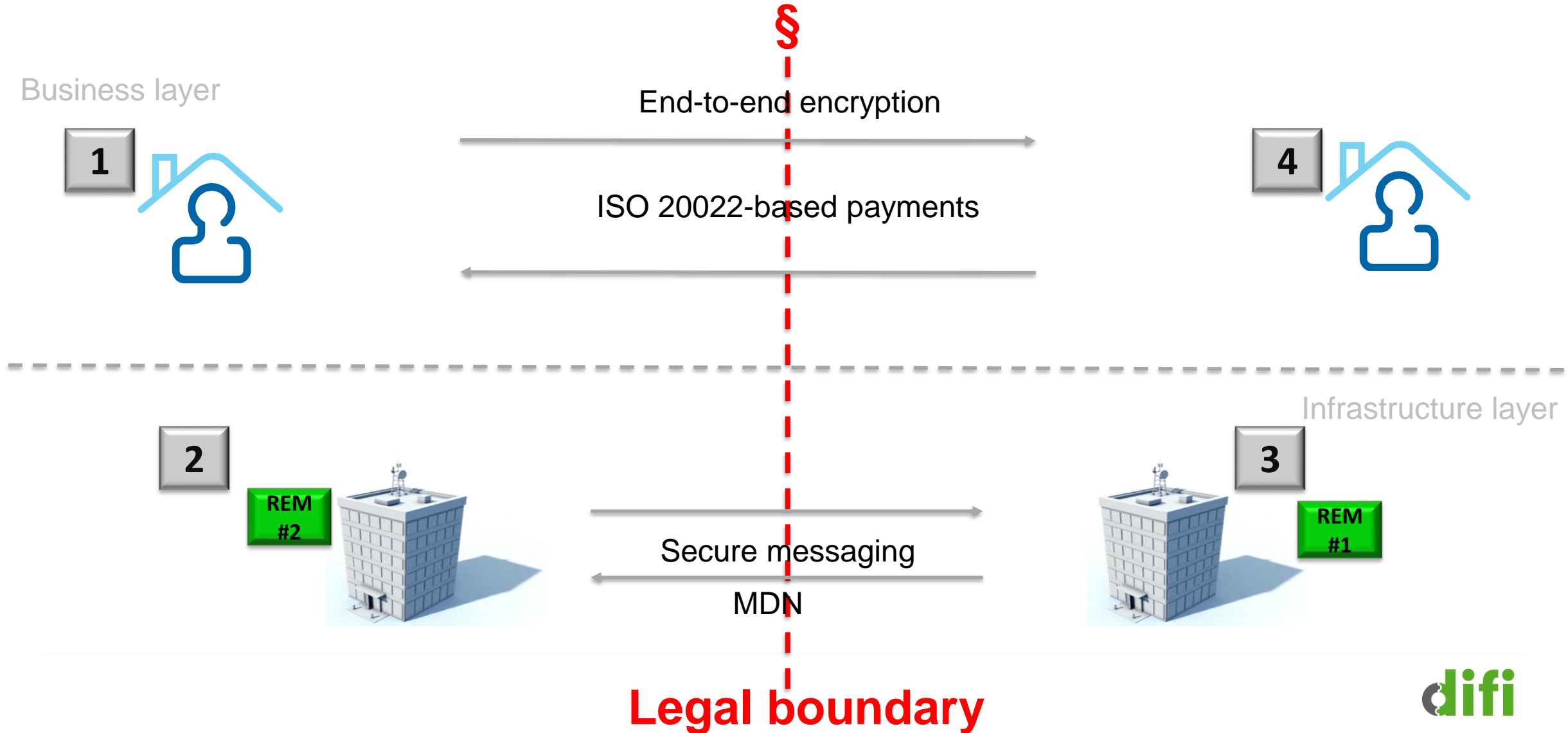

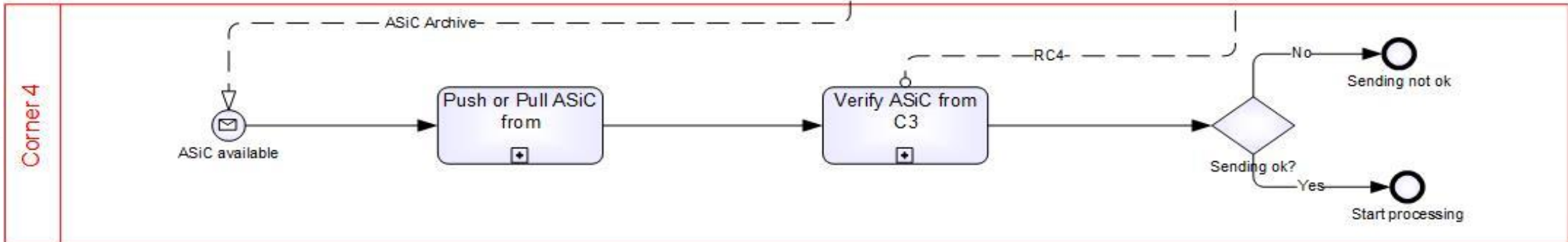
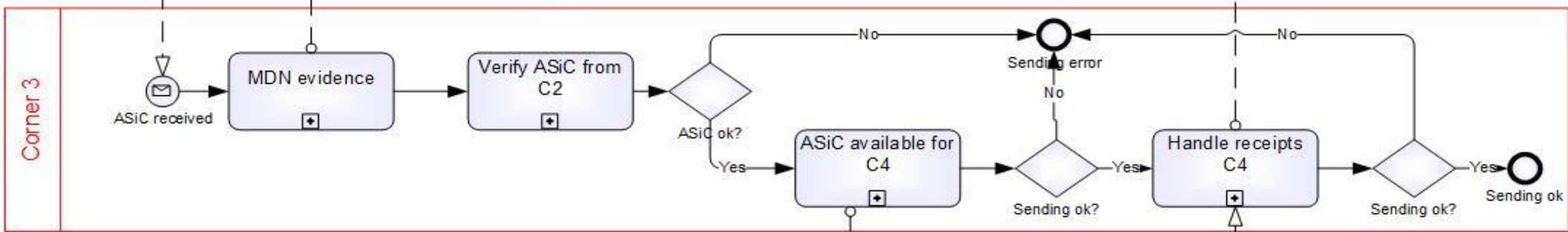
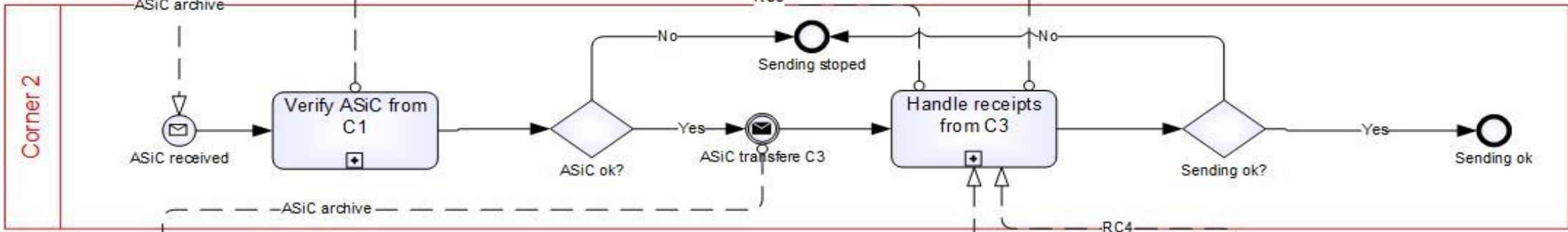
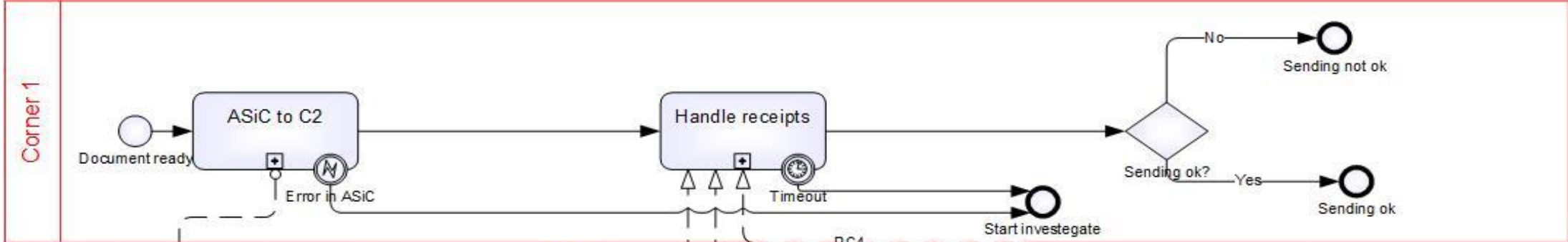

PROPOSED TIMELINE

Proposed time line from Difi

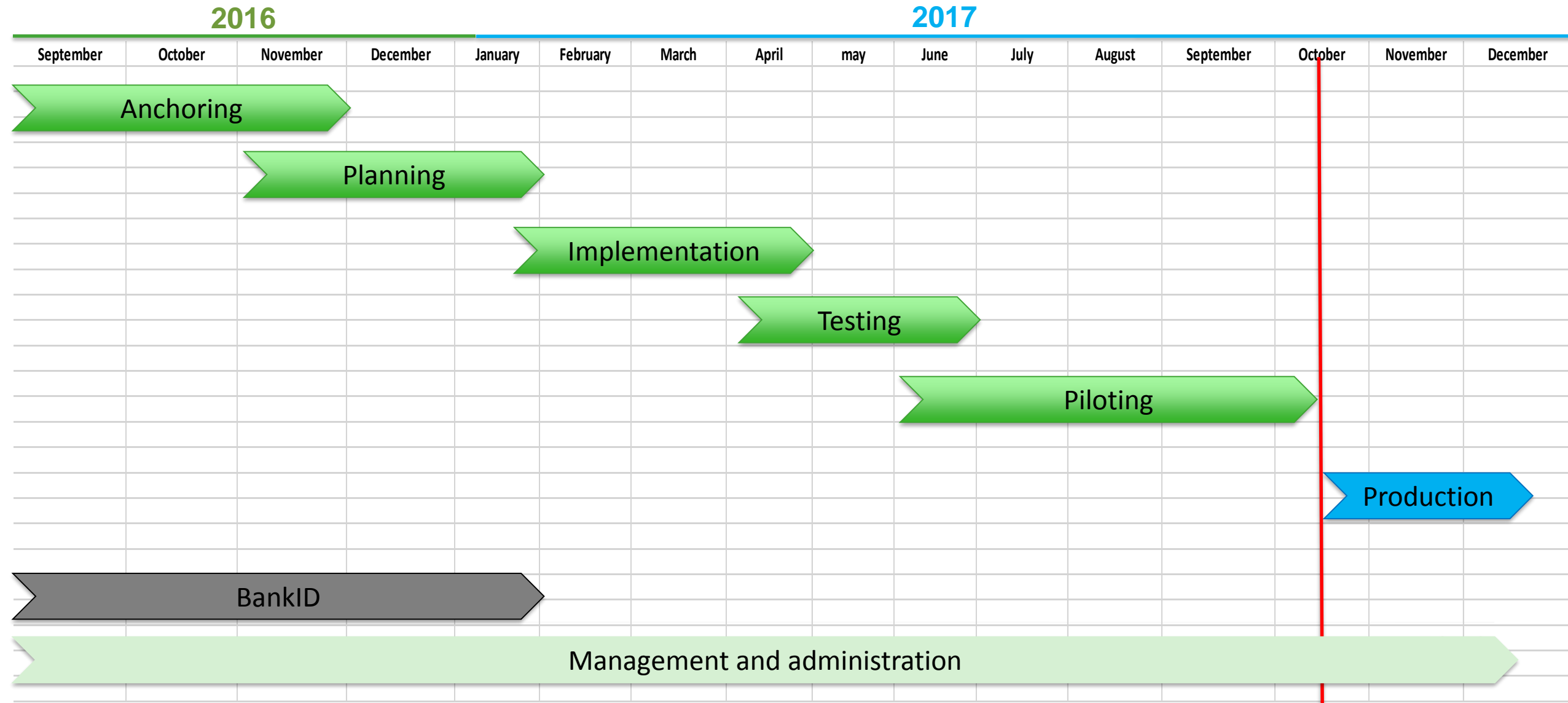

Proposed time line from NAV

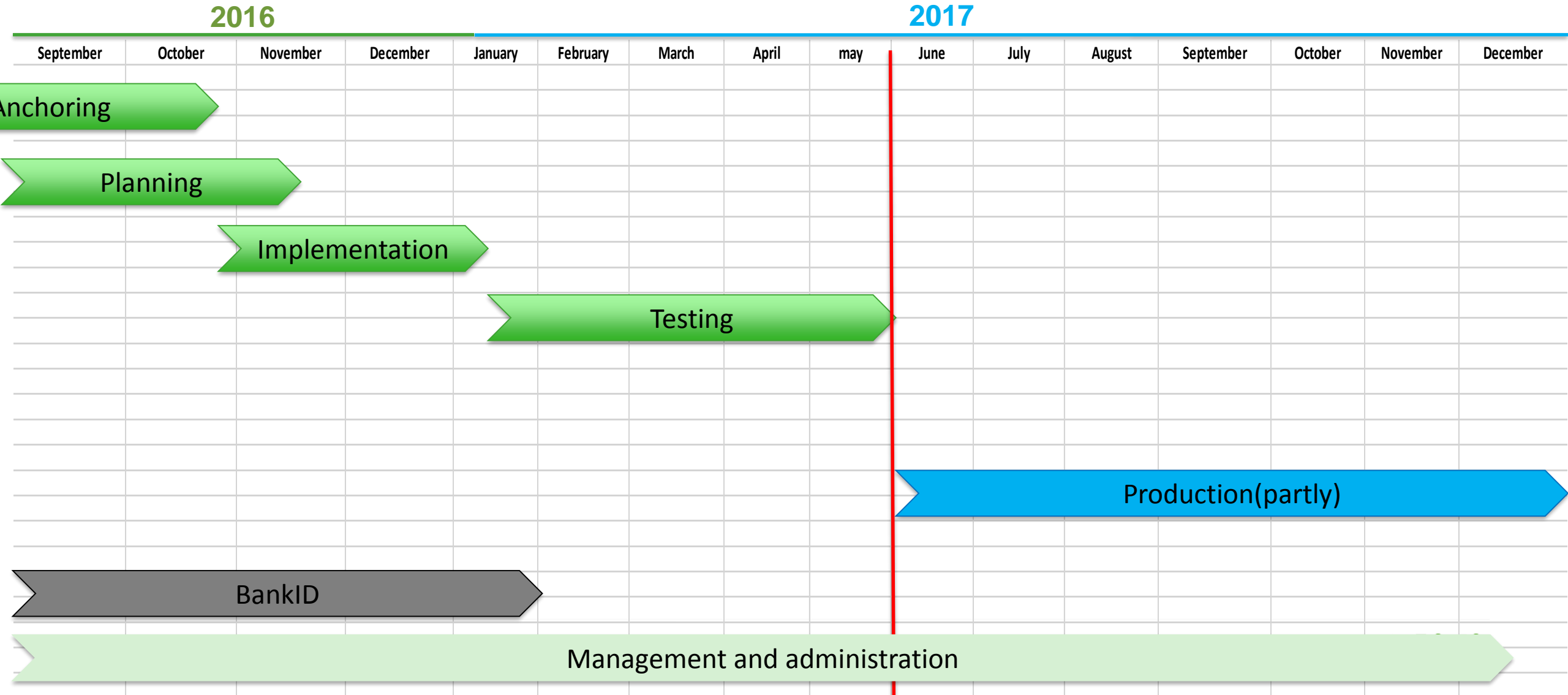

Timeline

Seen from the banks perspective

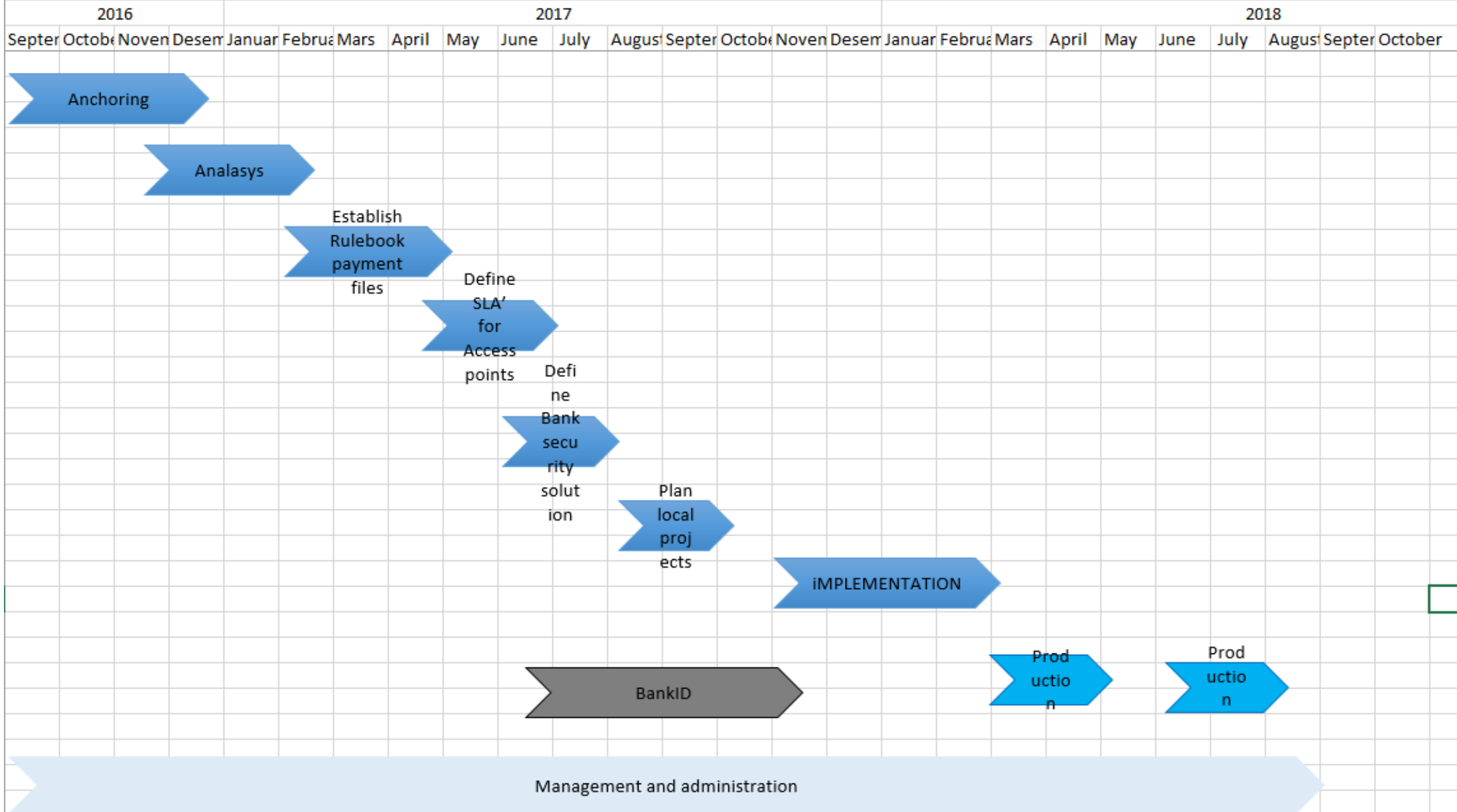

FURTHER WOORK

SEPA payment access point

- ▶ Approval process
- ▶ New SLA
- ▶ Test of Difi Certificate Server
- ▶ Modified MDN
- ▶ REM
- ▶ Receipts
- ▶ Annex 5 in PEPPOL TIA
- ▶ Additional access point?
- ▶ Reporting

Banks and ERP vendors

- ▶ Encryption and decryption
- ▶ ASiC in ASiC archive
- ▶ Inner and outer SBDH
- ▶ Receipts handling
- ▶ Uploading company certificates

